

# PhidgetTextLCD with 8/8/8

Phidgets are the most user-friendly system available for controlling and sensing the environment from your computer. People with absolutely no hardware knowledge or experience can include text displays into their projects. It is just a matter of plugging your PhidgetTextLCD into the USB port on your computer. After that, you can use the simple to program Phidgets software libraries to access these devices.

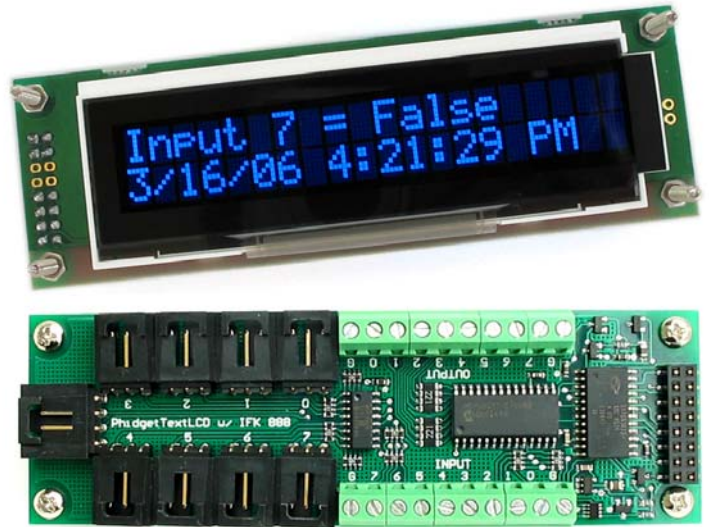

A PhidgetTextLCD is a two line by 20-character Liquid Crystal Display (LCD) text screen; green, blue, and white backlit versions are available. In addition, on the back, the PhidgetTextLCD includes a PhidgetInterfaceKit 8/8/8. This Interface Kit is equipped with:

- 8 Digital Inputs
- 8 Analog Inputs
- 8 Digital Outputs

The PhidgetTextLCD can be controlled from Windows, Linux, and Mac OS X. High-level programming interfaces are available for Visual Basic, C, C++, Flash, .NET, Java, LabVIEW, etc.

## What Can the PhidgetTextLCD Do?

On the LCD you can display results, messages, anything that will fit in two lines of twenty characters. Digital inputs can be used to convey the state of push buttons, limit switches, relays. Any sensor that returns a signal between 0 and 5 volts can be easily interfaced to the Analog Inputs. Digital outputs can be used to drive LEDs, solid-state relays, transistors; anything that will accept a CMOS signal.

# Getting Started on Windows 2000 / XP

The PhidgetTextLCD can be controlled from a variety of Software Development Environments. In Visual Basic the PhidgetTextLCD software component provide a high-level programmer interface. Here is how to get started under Windows 2000 or Windows XP.

## Step 1. What you need to have ready

- Your PhidgetTextLCD.
- A piece of wire to test the digital input (for the optional Interface Kit).
- An LED to test the digital output (for the optional Interface Kit).
- A USB cable.
- A computer running Windows 2000 or Windows XP.
- An Internet connection and a Web browser.

## Step 2. Assemble your hardware

- Plug the flat end of the USB cable into the input connector on the PhidgetTextLCD.
- Plug the rectangular end of the USB cable into the USB connector on your computer (you can do this at any time).

## Step 3. Install the software

Phidgets use a library installed on your computer. This library only has to be installed once, no matter how many different types of Phidgets you have.

- Have you previously installed the Phidget library? If so, you can skip this step.
- To install the library go to [www.phidgets.com](http://www.phidgets.com) >> Downloads >> Release.
- Select the PHIDGET.msi file.
- A dialog box will appear asking if you would like to open the file or save it to your computer. You can do either, but if you are unsure just select "Open" and follow the instructions.
- Do you want to update a previously installed Phidget library? If so, you must remove the old library when prompted to do so.

## Step 4. Download the sample programs

- Go to [www.phidgets.com](http://www.phidgets.com) >> Downloads >> Release.
- Select the Examples.zip file.
- Save the zip file to a place of your choosing, and then uncompress it.
- You will find many executables in the Visual Basic folder, and their source in the sub-folders.
- PhidgetMonitor.exe will show you what Phidgets are plugged in. If you have followed Step 2 and Step 3, a PhidgetTextLCD and a PhidgetInterfaceKit should be displayed in the list, along with a common serial number. The source for this .exe is in the PhidgetManagerExamples folder.
- All PhidgetTextLCD samples have a "TextLCD" prefix, and all PhidgetInterfaceKit samples have an "interface" prefix. Try them! All source code can be found in the PhidgetTextLCDExamples and PhidgetInterfaceKitExamples folders.

## Step 5. Try Programming a Phidget

- Go to [www.phidgets.com](http://www.phidgets.com) >> Documentation.
- Read the API manual for the Programming language of your choice and read the documentation under the PhidgetTextLCD heading.
- Based on this documentation, we recommend you examine the source of the sample programs mentioned in Step 4.
- Now try modifying the samples. Or code your own from scratch.

## Step 6. Learning more ...

- Explore [www.phidgets.com](http://www.phidgets.com). We recommend you visit Projects and Examples to see what other people have done. For new applications or other programming languages visit the Forums.

## Step 7. Read the license agreement

Go to [www.phidgets.com](http://www.phidgets.com) >> Documentation and select the License link. Note that the term Phidget™ is trademarked, and that the name PhidgetTextLCD is synonymous with Phidget™.

## Using the Phidget Interface Kit 8/8/8

While the Interface Kit and its off the shelf devices will satisfy almost all needs, the occasional developer may want to include a switch or output type that is not available through Phidgets. Fortunately, this is still very easy to do, and only a rudimentary knowledge of electronics is needed. Read on!

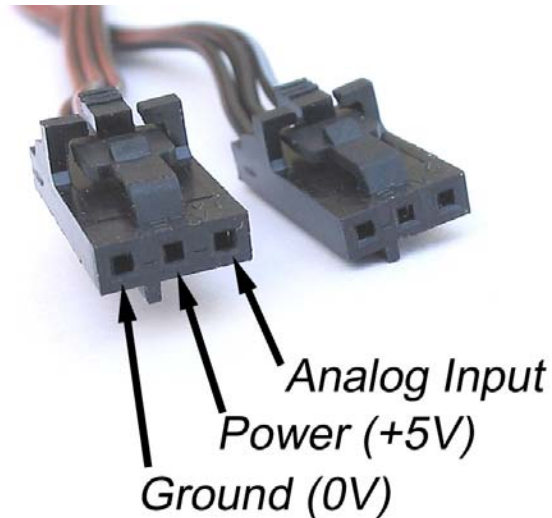

### Using the Analog Inputs

The Analog Input can measure a voltage between 0V and 5V. The analog measurement is represented in the software as a value between 0 and 1024, so a sensor value of 1 unit represents a voltage of approximately 5 millivolts.

Each analog input uses a 3-pin, 0.100-inch pitch locking connector. Pictured here is a plug with the connections labeled. If this is wired backwards, damage to your sensor may result. The Interface Kit provides + 5 VDC, ground, and an analog input with a range of 0 to 5V.

We offer an expanding line of packaged sensors that can be plugged directly into the analog inputs. Experienced users are encouraged to interface their own sensors.

The connector is manufactured by Molex, part number 50-57-9403 and 16-02-0102 for the wire crimp insert, and is available from many sources including [www.DigiKey.com](http://www.DigiKey.com) (Digi-Key part numbers WM2901-ND and WM2510-ND).

### Using the Digital Inputs

To wire a switch to a digital input, connect the switch between an input, labeled 0 to 7, and a provided ground, labeled G. When the switch is closed, or electrical contact is made, software will report this as a `DigitalInputChanged` event, reporting `True` for this input.

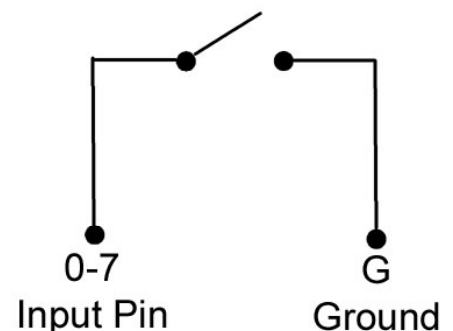

### Using the Digital Outputs

Connecting a LED or other circuit to a digital output is simple. In the case of an LED, wire the anode to a digital output labeled 0 to 7 on the Interface Kit, and the cathode to a supplied ground, labeled G.

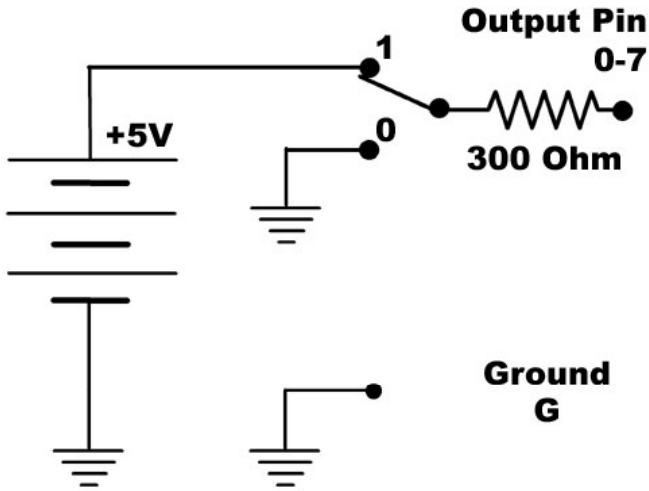

The 300 ohm resistance is internal to the PhidgetInterfaceKit 0/8/8, and limits the current that can flow through the output. This is intended to protect the device from being damaged if there is a short to ground or if an LED is used. The output is intended to drive TTL or CMOS inputs; it is not designed to provide power to an external circuit.

The digital outputs can be used to switch larger electrical currents and voltages using devices such as power transistors, or logic level MOSFETS.

## Hardware Description

The PhidgetTextLCD's are 2 line x 20-character Liquid Crystal Displays (LCD) with LED backlighting. Software libraries will recognize the Phidget-TextLCD and PhidgetInterfaceKit 8/8/8 as two separate devices with the same serial number. When programming, both devices need to be opened before they can be used. The LCD's currently used are:

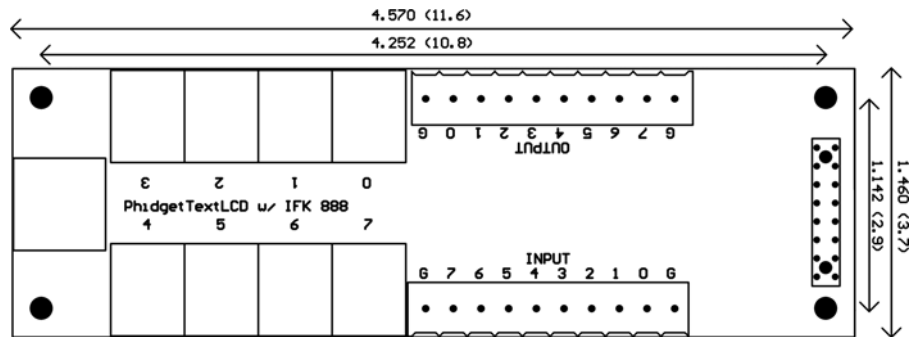

Height of display plus Interface Kit: 2.7 cm.

Colour	Manufacturer	Part number
Blue	Optrex	C-51505NFQJ-LB-AE
Green	Optrex	C-51505NFQJ-LG-AF
White	Optrex	C-51505NFQJ-LW-AD

## Device Specification

Digital Output Resistance	300 ohm
Digital Output Update Rate	Approx. 125 Hz
Digital Input Update Rate	125 Hz
USB Current Consumption	Max. 300 mA